

Molecular Blood Group Typing: Methods and Indications

Christoph Gassner

Blutspende Zürich, Schlieren, Switzerland

Tuesday, September 11th 2012 in Graz, DGTI, Östriich



Geno- meets Phenotype in blood group typing in ~ 1990

Nature. 1990 May 17;345(6272):229-33.

Molecular genetic basis of the histo-blood group ABO system.

Yamamoto F, Clausen H, White T, Marken J, Hakomori S.

Biomembrane Institute, Seattle, Washington.

Abstract

The histo-blood group ABO, the major human alloantigen system, involves three carbohydrate antigens (ABH). A, B and AB individuals express glycosyltransferase activities converting the H antigen into A or B antigens, whereas O (H) individuals lack such activity. Here we present a molecular basis for the ABO genotypes. The A and B genes differ in a few single-base substitutions, changing four amino-acid residues that may cause differences in A and B transferase specificity. A critical single-base deletion was found in the O gene, which results in an entirely different, inactive protein incapable of modifying the H antigen.

Proc. Natl. Acad. Sci. USA
Vol. 89, pp. 10925–10929, November 1992
Medical Sciences

Molecular cloning and primary structure of the human blood group RhD polypeptide

(erythrocyte membrane/RhD antigen/cDNA/gene analysis/PCR)

CAROLINE LE VAN KIM, ISABELLE MOURO, BAYA CHÉRIF-ZAHAR, VIRGINIE RAYNAL, CATHERINE CHERRIER, JEAN-PIERRE CARTRON*, AND YVES COLIN

Unité Institut National de la Santé et de la Recherche Médicale U76, Institut National de Transfusion Sanguine, 6 rue Alexandre Cabanel, 75015 Paris, France

Reasoning for molecular blood group typing

blood

2009 114: 248-256
Prepublished online May 1, 2009;
doi:10.1182/blood-2008-11-146860

Red cell genotyping and the future of pretransfusion testing

David J. Anstee

Table 1: Useful applications of red cell genotyping in transfusion medicine

- Fetal DNA typing
- Extensive blood group typing of donors for alloimmunized patients
- Determining the blood group of a recently transfused patient
- Screening blood donors to find rare blood group phenotypes
- Determining the frequency of blood group polymorphisms in a population
- Determining *RHD* zygosity for fathers of fetuses at risk for HDFN
- Blood group typing of patients with autoimmune hemolytic anemia

Arten und Anzahl Untersuchungen Mol BG Innsbruck 1994-2009 (ca. 50'000 Ery-Conc. / Jahr)

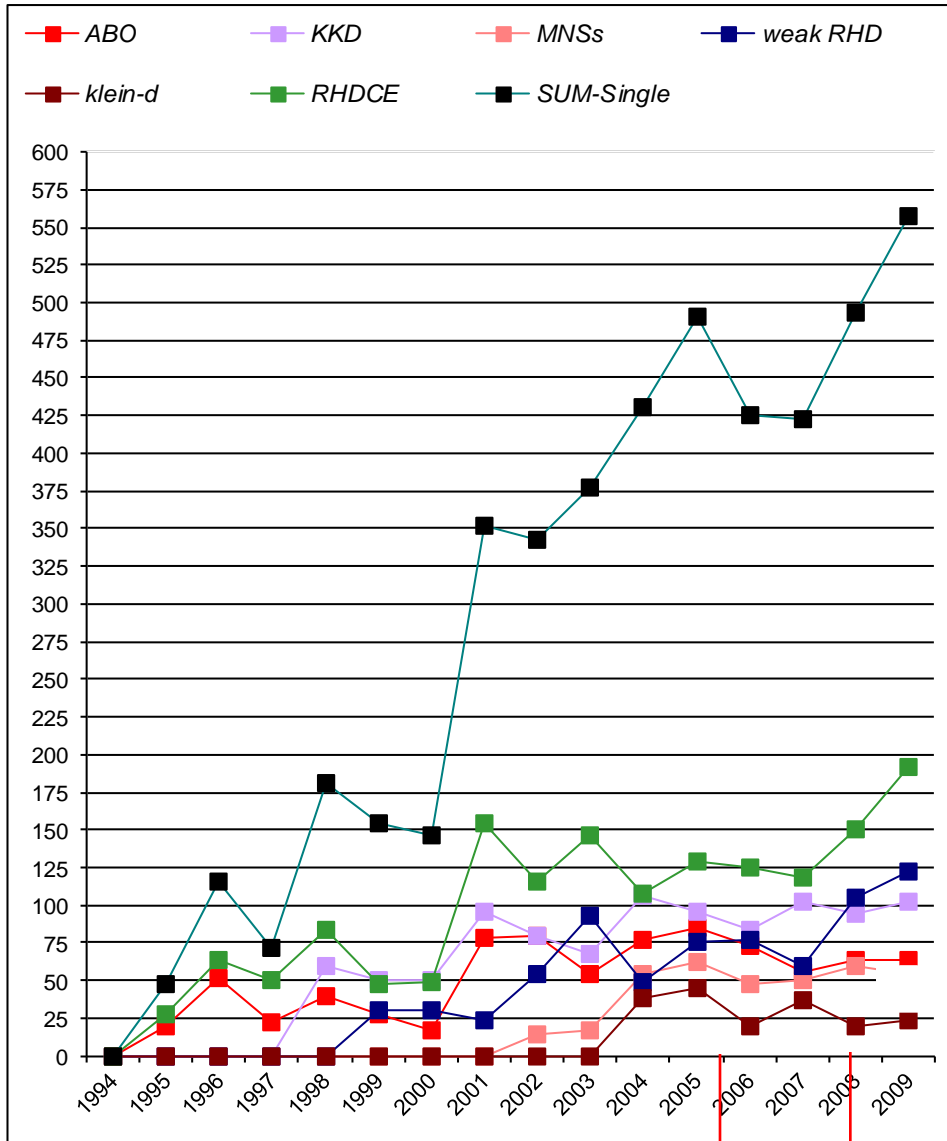

Pipette 2009

Blutgruppendiagnostik auf molekularer Ebene

Christoph Gassner

Sonderheft
Transfusionsmedizin
der

pipette
SWISS LABORATORY MEDICINE
Nr. 4, August 2009

Tabelle 1

Exemplarische Übersicht der Begründungen für die Untersuchung molekularer Blutgruppen in 1162 Fällen.

Haupt-Begründung	n	%	Detail-Begründung	n	%
Abklärung ABO, fehlende Isoaggl.	77	6,6%	hiervon Abklärung weak A	28	36,4%
Abklärung KEL	23	2,0%			
Abklärung FY	8	0,7%			
Abklärung RARE	20	1,7%	hiervon Abklärung LU	8	40,0%
Abklärung RHCE	25	2,2%	hiervon Abkl. weak RHC	18	72,0%
Abklärung RHD	314	27,0%	hiervon Abkl. weak RHD	233	74,2%
Bestimmung RHD-Zygotie	9	0,8%			
Bestimmung HPA	28	2,4%			
«Ery-Beladung mit AK (pos. DCT)»	151	13,0%			
«vortransfundiert»	183	15,7%			
Ringversuche	64	5,5%			
Sicherung Referenz-DNA	118	10,2%			
Andere Gründe als oben	110	9,5%			
Befund fehlt	32	2,8%			
	1162	100,0%			

Detection of SNPs by Polymerase Chain Reaction using Sequence Specific Priming (PCR-SSP)

GAGGGCGATTTCTACTACCTGGGGGGGTTCTTCGGGGGGTTCGGTGCAAGAGGTG
← CCAAGAAGCCCCCAGCC-5'

GAGGGCGATTTCTACTACCTGGGGGGCGTTCTTCGGGGGGTTCGGTGCAAGAGGTG
X CAAGAAGCCCCCAGCC-5'
C

Specificity of the PCR-SSP relies on the relative inability of the TAQ-Polymerase to start polymerisation from 3' mismatched primers...

Every mutation (SNPs) needs to be detected in an individual PCR-SSP.

PHENO- and GENOtyping before and after massive transfusion

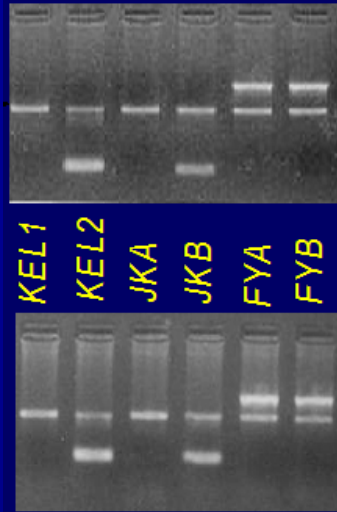
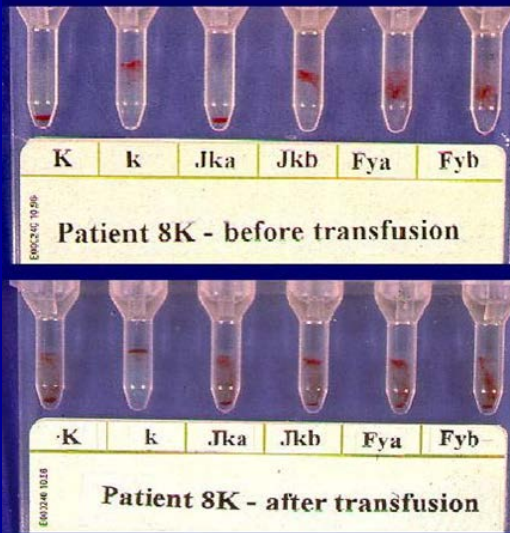

IMMUNOHEMATOLOGY

Differentiation of autologous *ABO*, *RHD*, *RHCE*, *KEL*, *JK*, and *FY* blood group genotypes by analysis of peripheral blood samples of patients who have recently received multiple transfusions

P. Rožman, T. Dovč, and C. Gassner

936 TRANSFUSION Volume 40, August 2000

Case	Patient	Units (22)
	kk	Kk (2)
	Jk(a-b+)	Jk ^a pos (17)
	Fy(a+b+)	all compatible

“The posttransfusion genotyping results were not influenced by either the amount of blood transfused in a transfusion event (range, 1-36 units) or the sampling period after a transfusion event (range, several hours-24 days).”

General **NON**-white blood cells reduced blood units

	range	average
Transfusion events	2 - 6	3.0
Units per 1 transfusion	1 - 36	7.9
Age of units	1 - 25d	5.2d
Sampling after transfusion	0 - 24d	4.7d



D in the erythrocyte membrane ...

regular D

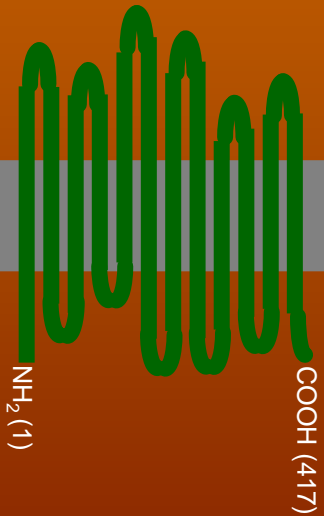

**category
partial D**

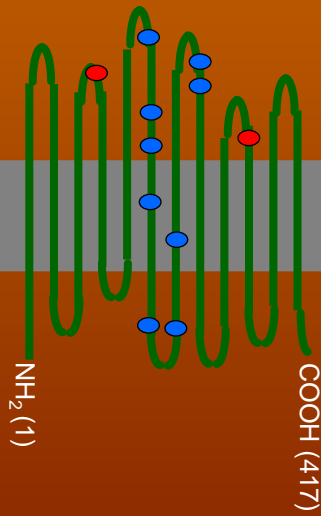

weak D

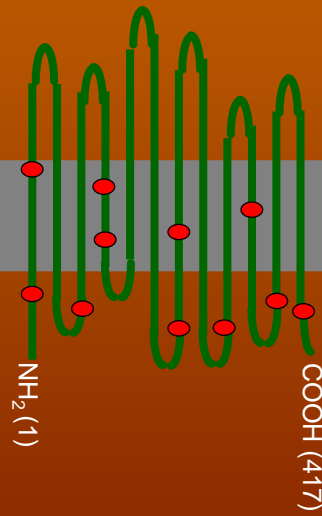

DEL

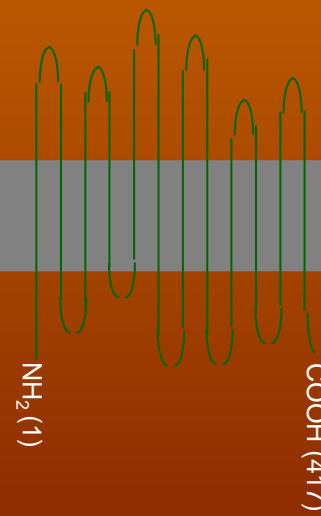

dd

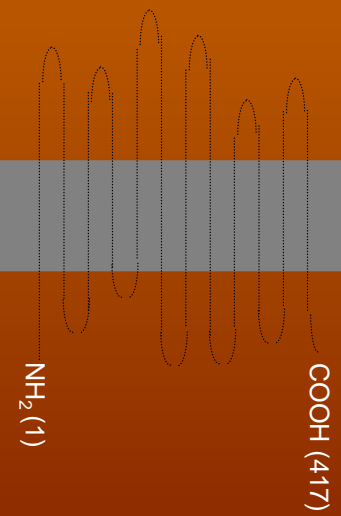

inner side

Blutgruppendiagnostik auf molekularer Ebene

Christoph Gassner

Sonderheft
Transfusionsmedizin
der

pipette
SWISS LABORATORY MEDICINE
Nr. 4, August 2009

Tabelle 1

Exemplarische Übersicht der Begründungen für die Untersuchung molekularer Blutgruppen in 1162 Fällen.

Haupt-Begründung	n	%	Detail-Begründung	n	%
Abklärung ABO, fehlende Isoaggl.	77	6,6%	hiervon Abklärung weak A	28	36,4%
Abklärung KEL	23	2,0%			
Abklärung FY	8	0,7%			
Abklärung RARE	20	1,7%	hiervon Abklärung LU	8	40,0%
Abklärung RHCE	25	2,2%	hiervon Abkl. weak RHC	18	72,0%
Abklärung RHD	314	27,0%	hiervon Abkl. weak RHD	233	74,2%
Bestimmung RHD-Zygotie	9	0,8%			
Bestimmung HPA	28	2,4%			
«Ery-Beladung mit AK (pos. DCT)»	151	13,0%			
«vortransfundiert»	183	15,7%			
Ringversuche	64	5,5%			
Sicherung Referenz-DNA	118	10,2%			
Andere Gründe als oben	110	9,5%			
Befund fehlt	32	2,8%			
	1162	100,0%			

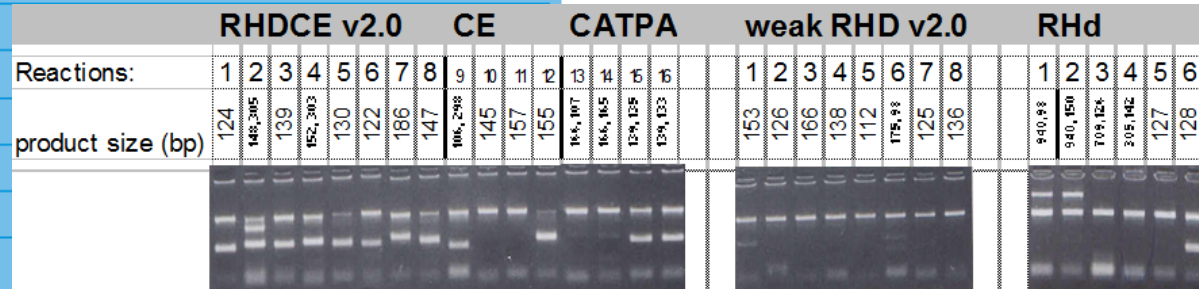

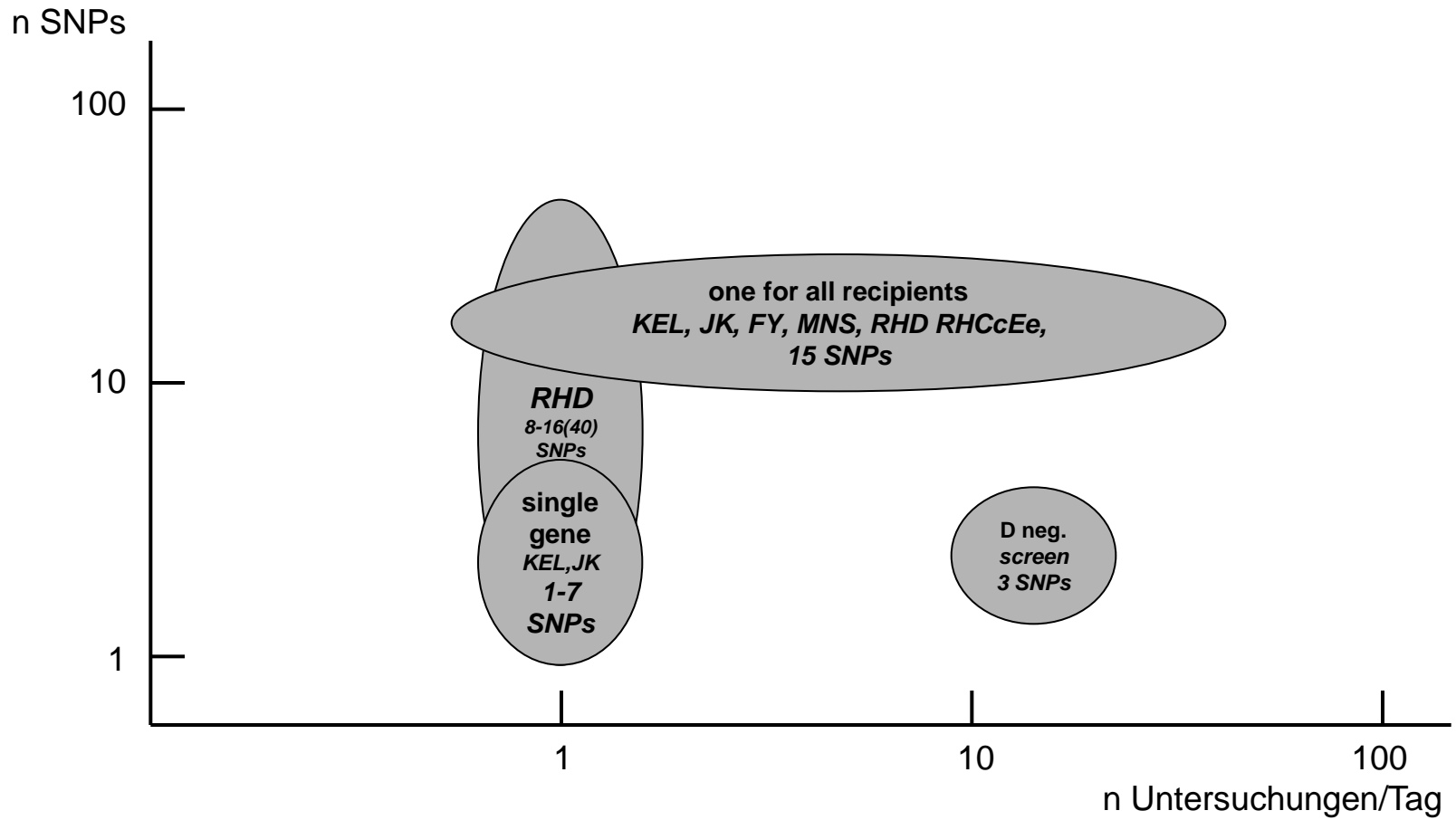

Do not transfuse D pos blood to D neg recipients!

CASE REPORT

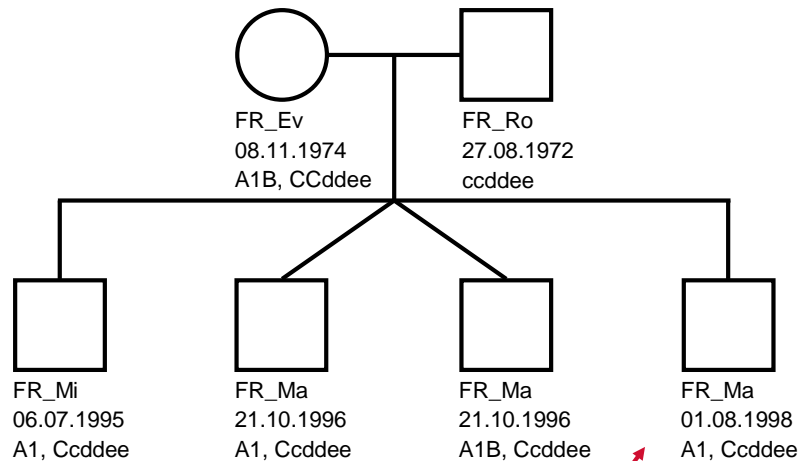

During 3rd pregnancy mother FR_Ev 08.11.1974 received 3 RBC units of CCddee phenotype (01.08.1998):
LU-Id 29.12.1935
SO-He 13.05.1952
TS-He 02.05.1945

During CCddee retesting in March 2002, LU-Id 29.12.1935 showed a weak D in ICT.
DNA testing showed a RHD gene of unknown specificity.

Consequently, serum of mother FR-Ev 08.11.1974 was investigated and showed allo-anti D:
++, standard LISS COOMBS (37°)
++++, papainised COOMBS

3 RBCs

Towards routine mass-application: **SCREENING** of D negative donors.

Screening for *RHD* among D negative Caucasians and Asians



Transfusion. 2009 Apr;49(4):676-81.
Polin H et al
Upper Austria AT

Transfusion. 2009 Mar;49(3):465-71.
Flegel WA et al
Baden-Württemberg

Transfusion. 2005 Apr;45(4):527-38.
Gassner C et al
Switzerland, Tyrol AT, Slovenia, Northern
Germany, Braunschweig, Kirov RU

BMC Genet. 2001;2:10.
Wagner FF et al
Baden-Württemberg

Results of Bern & Zurich Investigations, 2005 to 2012, (alleles complete)

		2001	2005	2009	2009	2009	SUM	2002	2004	2005	2005	2006	2008	SUM	2005	2007	2012-	2009	2012-	SUM	
SAMPLES WITH RHD GENE		ULM	IBK	IBK	ULM	LINZ		Guang-dong	Tainan Taiwan	Seoul Korea	Shan-dong	Gwan-g-JU	Fujian		BE Stu I	BE Stu II	BE	ZH	ZH		
SUM: with big letters		753	1700	960	2999	1934	8346	52	132	107	25	51	46	413	652						
SUM: ccddee		7688	0	0	43038	21396	72122	50	162	157	49	72	58	548	17391						
SUM: all		8441	1700	960	46037	23330	80468	102	294	264	74	123	104	961	652	17391	11565	8200	3610	41418	
Hybrid genes	C c dd e e RHD-CE(2-7)-D1	2					2										1			1	
	C c dd e e RHD-CE(2-9)-D1	3	39	16		11	69			1				1	2	5	16		2	2 LU	25
	C c dd e e RHD-CE(2-9)-D2	8				1	9	8	15	22	5	12	9	71							
	C c dd e e RHD-CE(3-9)-D					1	1									2	3				5
	C c dd e e RHD-CE(2-8)-D		4				4										1				1
	C c dd e e RHD-CE(3-7)-D																	3			3
	c c dd E e RHD-CE(3-7)-D, (3-8)																		2	1 LU	2
	C c dd e e RHD-CE(3-7)-D, Cde ^s	1					1									1		1			2
	C c dd e e RHD-CE(4-9)-D					2	2									2					2
	c c dd E e RHD-CE(4-9)-D															1					1
	c c dd E e RHD-CE(4-7)-D1	3	1				4													1	1
	C c dd e e RHD-CE(4-7)-D	1					1												1		1
c c dd E e RHD-CE(8-9)-D	3			17		20														1	
RHD Null	c c dd e e D neg: RHD psi	1			14	3	18									4	6	5			15
	c c dd E e D neg: RHD(W16X)	2			2		4										4	1	1		6
	C c dd e e D neg: RHD(343delC)				2		2									1					1
	? ? dd ? ? D neg: RHD(489delAGC)																2				2
	c c dd e e D neg: RHD 545(delICTGT)															1					1
C c dd e e D neg: RHD(R318X)				2		2											1				1
RHD DEL	C c dd e e DEL: RHD(M295I)	7	8	4	14	2	35									4	7	5	2	2 LU	18
	? ? dd ? ? DEL: RHD(M295T)																3				3
	C c dd e e DEL: RHD(IVS3+1g>a)	3	6		16	24	49									3	1	3	4		11
	C c dd e e DEL: RHD(IVS3+5g>a)																1	1			2
	C c dd e e DEL: RHD(IVS5-38del4)															2					2
	C c dd e e DEL: RHD(K409K)	5			4	1	10	35	94	42	22	16	27	236				2	1		3
C c dd e e DEL: RHD-CE(10), or del ex 10																	1			1	
RHD weak, parti	C c dd e e RHD partial DVL-2															2		4	1	1 LU	7
	c c dd e e weak D type 4.3					31	31														
	c c dd E e weak D type 5		2			1	3														3
	C c dd e e weak D type 31															1		2			
	C c dd e e weak D type 32					2	2														
C c dd e e weak D type 38																1	1	1			3
C c dd e e regular RHD ?	? ? dd ? ? RHD-CE(2)-D		9	1	1		11														
	? ? dd ? ? RHD(P291R)															1					1
	? ? dd ? ? not yet specified																2				2
	SUM	45	89	21	96	94	345	47	109	68	28	29	38	319	23	18	57	23	9	130	

RhD-Screening at the ZHBSD

Pooled blood sample screening (Wagner et al., 2001)

★ Single blood sample screening

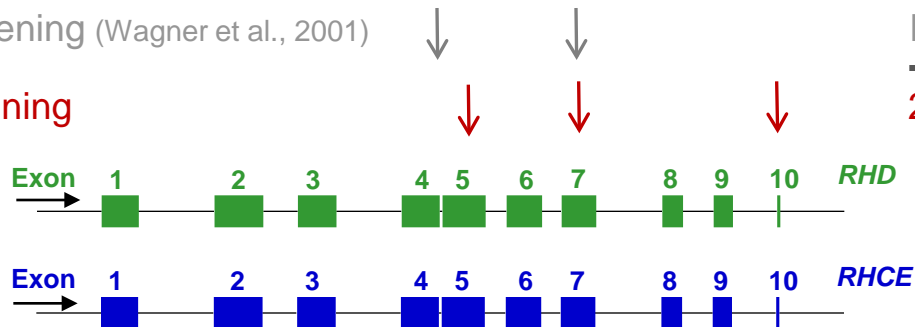

III 2009 - 2011 ↓

2012 on ... ↓

★ 1. Preparation of 95 **single** DNAs (microtiter plate)

2. PCR-Test
Exon 5 & 10

3. PCR-Test Exon
7 & B-Allel

Exon 10 →
Exon 5 →

← Exon 7

← B-Allel
(proof of
position)